

Saramonic

**Ultimate 2-channel Wireless
Microphone System**

双通道旗舰无线麦克风系统

Saramonic Ultra

User Manual

用户手册

Statement

Please read this manual carefully before using, and strictly operate and store it in accordance with the instructions. Please save the manual for future reference. If you need further assistance than the user manual, please consult your retailer for help or email us at: info@saramonic.com

Cautions

1. Non-professionals are strictly prohibited from disassembling this unit on their own.
2. Please keep it away from heat sources such as radiators or spotlights.
3. Do not remove the battery without professionals' help.
4. Please clean the unit with only a soft, dry cloth.
5. When using and storing, please keep away from dust and moisture.
6. For the best pick-up pattern, do not hold your hand against the microphone capsule cover.

General Introduction

Saramonic Ultra, a portable ultimate 2-channel wireless microphone system, provides professional-quality sound within 300 meters* of transmission range. It is ideal for broadcasting, presentations, mobile journalism and more. The system adopts a new self-developed noise cancellation algorithm and low-cut sound mode to effectively eliminate background noise. The transmitter of this system is IPX5-rated for water resistance, performing well in harsh environments.

Saramonic Ultra comes with 32-bit float on-board recording, timecode, and more advanced settings. The 32-bit float on-board recording supports the transmitter recording audio independently, which is available for storing the recording files in real time. Its timecode keeps your video and audio flawlessly synchronized in post-production. The receiver comes with a 1.1-inch touchscreen, displaying information such as wireless signal strength, noise cancellation,

battery, volume, time code, recording status, etc. Users can easily adjust various parameters during the recording process.

Saramonic Ultra boasts extensive compatibility. The transmitter incorporates an in-built microphone, and can be connected to an external lavalier microphone (some packages do not include this lavalier microphone; please refer to the actual package purchased). The receiver has a 3.5 mm multi-functional output, which can output audio from the receiver to a camera or mixer. In addition, the included USB-C or Lightning adapter can be used to output audio from the receiver to a smartphone, tablet, or computer.

* Measured in an unobstructed environment without interference, and this data can only be achieved while using the external antenna.

Features

- Timecode sync
- 130 dB SPL
- External antenna, stable signal
- Noise cancellation, AGC
- 32-bit float REC, 8 GB storage
- IPX5 waterproof

What's in the Box

Saramonic Ultra 01 (Black)	
Transmitter	×2
Receiver	×1
Charging Case	×1
USB-C to USB-C Data Cable	×1
3.5 mm TRS to TRS Audio Cable	×1
Lightning Adapter	×1
USB-C Adapter	×1
Fur Windshield	×2
Magnet	×2
External Antenna	×1
Carrying Bag	×1

Saramonic Ultra 02 (White)	
Transmitter	×2
Receiver	×1
Charging Case	×1
USB-C to USB-C Data Cable	×1
3.5 mm TRS to TRS Audio Cable	×1
Lightning Adapter	×1
USB-C Adapter	×1
Fur Windshield	×2
Magnet	×2
External Antenna	×1
Carrying Bag	×1

Saramonic Ultra 03 (Black)	
Transmitter	×2
Receiver	×1
Charging Case	×1
USB-C to USB-C Data Cable	×1
3.5 mm TRS to TRS Audio Cable	×1
Lightning Adapter	×1
USB-C Adapter	×1
Fur Windshield	×2
Magnet	×2
External Antenna	×1
Lavalier Microphone	× 2
Carrying Bag	× 1

Saramonic Ultra 04 (White)	
Transmitter	×2
Receiver	×1
Charging Case	×1

USB-C to USB-C Data Cable	×1
3.5 mm TRS to TRS Audio Cable	×1
Lightning Adapter	×1
USB-C Adapter	×1
Fur Windshield	×2
Magnet	×2
External Antenna	×1
Lavalier Microphone	× 2
Carrying Bag	× 1

Saramonic Ultra 05 (Black)	
Transmitter	×1
Receiver	×1
Carrying Bag	×1
USB-C to USB-C Data Cable	×1
3.5 mm TRS to TRS Audio Cable	×1
Lightning Adapter	×1
USB-C Adapter	×1
Fur Windshield	×1
Magnet	×1
External Antenna	×1

Saramonic Ultra 06 (White)	
Transmitter	×1
Receiver	×1
Carrying Bag	×1
USB-C to USB-C Data Cable	×1
3.5 mm TRS to TRS Audio Cable	×1
Lightning Adapter	×1
USB-C Adapter	×1
Fur Windshield	×1

Magnet	×1
External Antenna	×1

Accessories (Sold Separately)	
Adapter for Connecting SONY Camera	
Lavalier Microphone	

Product Structure Transmitter (TX)

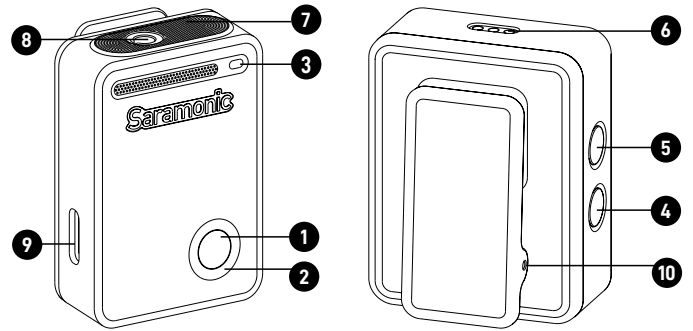

1 Power Button

- Press and hold for 2 seconds to power on or off.
- Press once to mute or unmute the transmitter.
- When the receiver is connected to a smartphone, the user can start or stop recording by pressing the transmitter's power button twice. Note that this feature only supports smartphones where the volume button can be used to take a photo.

2 Status Indicator

Status	Indicator
Unpaired	Blinks blue slowly
Paired	Solid blue
Noise cancellation enabled	Solid green
Low battery	Blinks red
Charging	Solid red
Fully charged	Solid blue or green
Pairing	Blinks blue rapidly

- In pairing mode, the status indicator will blink blue rapidly for 2 minutes waiting for pairing with the receiver. After the timeout, the transmitter will exit pairing mode, and its indicator will blink blue slowly.
- Please charge the transmitter when its status indicator blinks red, or it will automatically

shut down after 10 minutes.

- When multiple functions are activated on the transmitter, its indicator will give priority to displaying only one feature. The indicator is prioritized as follows: charging > low battery > unpaired > noise cancellation.

3 Recording Indicator

Status	Indicator
Mute on	Blinks red
Onboard recording enabled	Solid red
Failed to enable onboard recording	Blinks red 3 times and then turns off

- When reading the onboard recording files, onboard recording can not be enabled.
- The indicator is prioritized as follows: mute > onboard recording.

TIP: The recording indicator doubles as a charging status indicator when the transmitter is placed into the charging case for charging. See the chart below for more details.

Status	Indicator
Charging	Solid red
Fully charged	Off

4 REC Button

Press once to enable or disable onboard recording.

5 NC Button

Press once to activate or deactivate noise cancellation

6 Charging Contacts

Charging will begin when the charging contacts of the transmitter connect to the charging pins of the charging case.

7 In-built Microphone

8 3.5 mm TRS Input

For connecting an external lavalier microphone.

9 USB-C Charging port / Data Export

For charging the transmitter via the included USB-C to USB-C data cable. The user can read and download onboard recording files from the in-built storage card of the transmitter through this port.

10 Magnetic Clip

For attaching the transmitter to clothing, or using with the included magnet.

Receiver (RX)

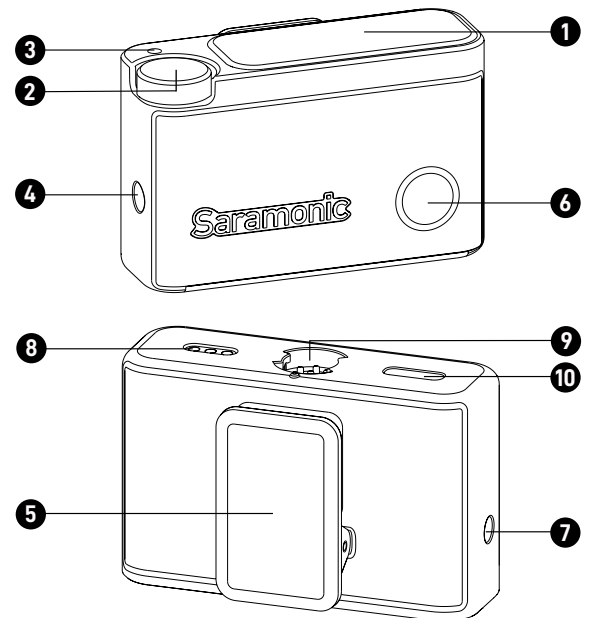

1 Touchscreen

Displays vital information such as wireless signal strength, noise cancellation, battery levels and charging status of the transmitters and receiver, gain, real-time volume, output mode, timecode. Refer to Receiver Touchscreen Operation for details.

2 Knob

When the receiver touchscreen is on the Settings Menu, rotate to select relevant settings, then press once to access sub menus.

3 Overload Indicator

It will glow solid red when the sound pressure level of the recording exceeds the designed value. And it will turn off if there is no overload volume for 1 second.

4 External Antenna Port

For inserting the external antenna provided.

5 Clip

Can be mounted on a cold shoe of a camera.

6 Power Button

- Press and hold for 2 seconds to power on or off.
- Press once to lock the screen to avoid unexpected operation during recording. Press again to unlock the screen.

7 3.5 mm Multi-functional Output

Supports Mono, Stereo, Safety Track, Headset, and Headphone output. The user can select one output mode among them. The default output mode is Mono. Refer to Receiver Touchscreen Operation for details.

8 Charging Contacts

Charging will begin when the charging contacts of the receiver connect to the charging pins of the charging case.

9 Connecting Contacts

Connect the receiver to a smartphone, tablet, computer, or other mobile device by using the Lightning / USB-C adapter provided.

10 USB-C Charging port

For charging the receiver via the included USB-C to USB-C data cable.

Charging Case

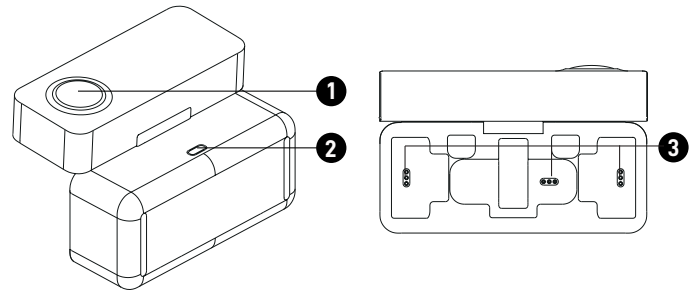

1 Indicator

- When the charging case is connected to power, this indicator will display the case's charging status.

Battery level (case)	Indicator
0 to 33%	Pulses red
34% to 76%	Pulses orange
77% to 100%	Pulses white
Fully charged	Solid white

- When the charging case is not connected to power (not in charging mode), opening the case or placing the transmitters and receiver into it for charging, this indicator will display the case's current battery level.

Battery level (case)	Indicator
0 to 10%	Flashes red (not pulse)
10 to 33%	Solid red
34% to 76%	Solid orange
77% to 100%	Solid white

! Note

1. Please charge the charging case as soon as possible when its indicator flashes red (not pulse). In that case, the charging case holds a low battery (<10%) that is unavailable for charging the transmitters and receiver.
2. When the battery level of the charging case is above 10% or when the case is connected to the USB-C to USB-C charging cable for charging, the transmitters and receiver will automatically turn on once removed from the case. The transmitters and receiver will automatically turn off if there is no operation in the case for 1 minute.

2 USB-C Charging Port

For charging the charging case via the included USB-C to USB-C data cable.

3 Charging Pins

Operation Guide

Placing Transmitter

- 1 The transmitter with an in-built microphone can be used with a fur windshield for capturing clear audio outdoors or in a windy environment. If the user wants to use an external lavalier microphone, please connect it to the transmitter's 3.5 mm TRS input.

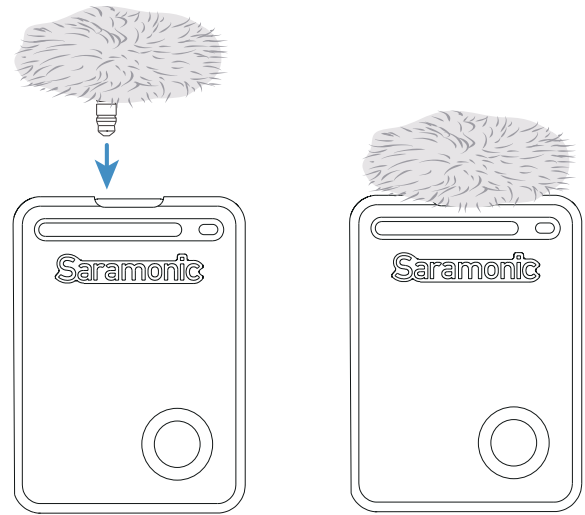

- 2 The transmitter can be directly attached to clothing via its magnetic clip, or using with the magnet, offering users greater flexibility when wearing the transmitter.

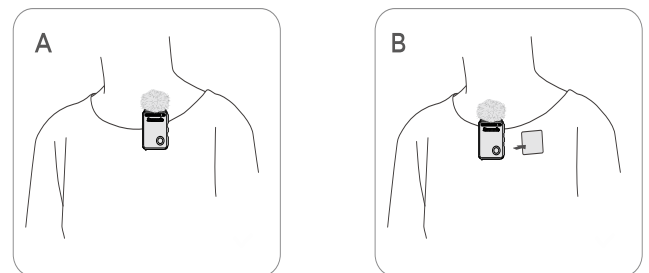

Antenna Installation

The receiver comes with an in-built antenna, and it can be inserted into an external antenna for use. The receiver will automatically use the external antenna while the in-built antenna is unavailable when the provided external antenna is inserted into the receiver's external antenna port. If you remove the external antenna, the in-built antenna will be in use.

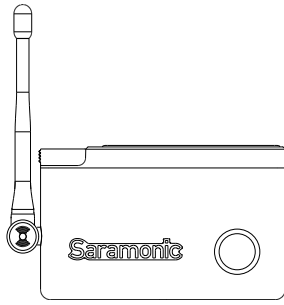

TIP: Using the included external antenna can effectively improve the anti-interference performance.

Pairing Transmitters and Receiver

The transmitters and receiver in the Saramonic Ultra system have been paired successfully by default. Therefore, the transmitters and receiver will be paired once they are powered on.

Transmitter's status indicators will be solid blue if paired successfully. Follow any of the methods below to pair the transmitters and the receiver if they become unpaired.

Method 1: Pair Automatically via Charging Case

Place the transmitters and the receiver in the charging case to pair them automatically. They will become paired after being placed into the case for 5 seconds.

Method 2: Pair Manually

- 1 Press and hold the transmitter's power button for 5 seconds in shutdown mode to make the transmitter in pairing mode with the receiver. In this mode, the status indicator on the transmitter blinks blue quickly.
- 2 Turn on the receiver by pressing its power button for 2 seconds, slide left on the touchscreen to enter the Settings Menu, then locate the Pairing menu, tap to access the sub menu, then tap Pairing.

- 3 If paired successfully, Transmitter's status indicators will be solid blue.

Using with a Mobile Device

- Mount the correct adapter on the receiver according to your device's port, and then connect the receiver to your smartphone, tablet, computer, or other mobile device. Launch the recorder or camera on the connected mobile device to start recording, the audio captured by the transmitter will be transferred to the mobile device. Additionally, the adapters support charging the phone when connected to power.

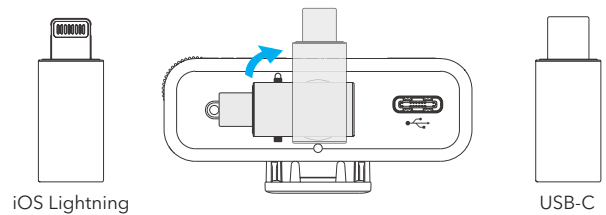

- When the receiver is connected to a smartphone or computer, the user can record audios or videos, and update or control both the transmitters and receiver via the Saramonic app.
- 1 Please scan the QR code below with your phone to install the Saramonic app.



- 2 Launch the Saramonic app, then tap the  icon to start recording.



- 3 Tap the  icon in the upper left corner, then tap "Saramonic Ultra Device Management" to enter the receiver (RX) and transmitter (TX) control page.

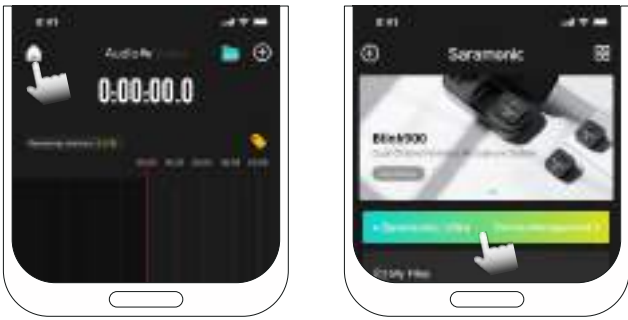

Control RX:



Swipe up on the screen to access TX1 and TX2 control:



- 4 Go to More Settings > Sound Modes, select Low Gain Mode. In this mode, the maximum sound pressure level can reach 130 dB, effortlessly preventing sound spikes and distortion, while significantly improving recording quality.

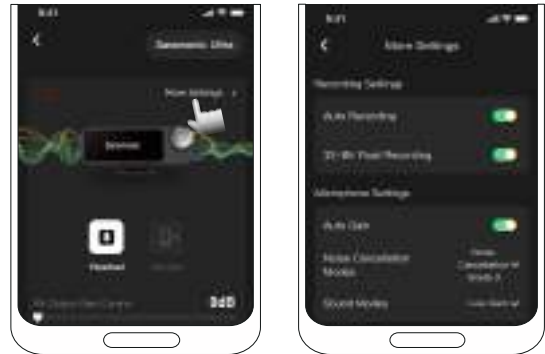

Using with a Camera

Use the included 3.5 mm TRS to TRS audio cable to connect the receiver's 3.5 mm multi-functional output to a camera, mixer. The audio captured by the transmitter will be transferred to the camera or mixer.

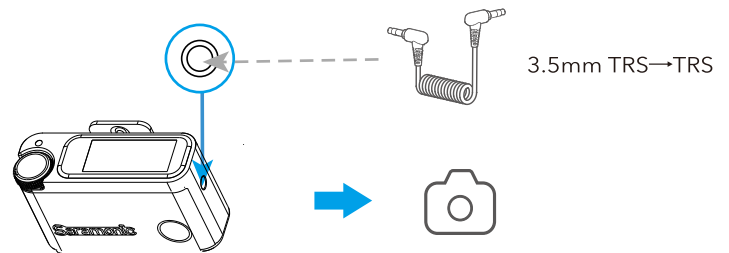



Receiver Touchscreen Operation

Home Screen Overview

The home screen displays wireless signal strength, noise cancellation, battery levels and charging status of the transmitters and receiver, real-time volume, output mode, auto gain, timecode. The following is an example of the touchscreen when the receiver is paired with two transmitters.



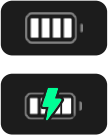

The top of the Home Screen indicates transmitter status.

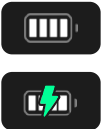
	<p>Indicates the current wireless signal strength between the transmitter 1 (TX1) or the transmitter 2 (TX2) and the receiver. If there is only one transmitter connected, then only the information of one transmitter will be displayed.</p>
	<p>Indicates that onboard recording is enabled.</p>
	<p>Indicates that noise cancellation of the transmitter is enabled.</p>
	<p>Indicates battery levels and charging status of transmitters.</p>



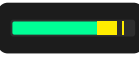

	<p>Indicates battery levels and charging status of the receiver.</p>
--	--

Quick Settings: On the Home Screen, press the receiver's knob once to select the top, the bottom part of the Home Screen or exit. The microphone gain can be adjusted quickly by rotating the knob when the top part is selected. The output volume can be adjusted quickly by rotating the knob when the bottom part is selected.

The middle of the Home Screen indicates transmitter volume.

	<p>Indicates the microphone gain.</p>
	<p>Indicates the volume of the real-time audio input.</p>
	<p>Indicates that the transmitter is muted.</p>

The bottom of the Home Screen indicates receiver status.

	<p>Indicates the output mode of the receiver. Refer to Settings Menu for details.</p>
	<p>Indicates the output volume.</p>
	<p>Indicates that the screen of the receiver is locked. Press the receiver's power button once to unlock or lock the screen.</p>
	<p>Indicates that the timecode is turned on.</p>
	<p>Indicates that the receiver has enabled headset noise cancellation.</p>

Menus Overview

If there is no operation within 20 seconds on menus, the touchscreen will automatically return to the Home Screen.

Transmitter Settings Menu

Slide down from the top of the left side of the Home Screen to adjust settings for the transmitter 1, and slide down from the top of the right side of the Home Screen to adjust settings for the transmitter 2. Tap the corresponding icons to control mute, noise cancellation, recording status.

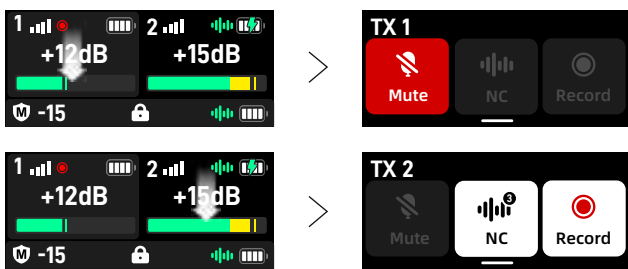







To return to the Home Screen from the Transmitter Settings Menu, slide up from the bottom of the screen.









Settings Menu



- Slide left from the Home Screen to access the Settings Menu.
- On the Settings Menu, slide right or left to select main menus. Or turn the knob on the receiver to select relevant menus.
- Tap relevant icons on main menus or press the knob once to access sub menus. Tap or select relevant settings to confirm selections.
- To return to the previous page from any other page, slide up from the bottom of the screen.

Main Menu	Sub Menu	Description
	Mono	Signal from the left and right channel are identical.
	Stereo	The left and right channel outputs correspond to the two sound sources of transmitter 1 and transmitter 2 respectively.
	Safety Track	The output gain of the right channel is 6 dB lower than that of the left channel to avoid audio level spikes in your recordings.
	Headset	The receiver's 3.5 mm multi-functional output can be plugged into a headset.
	Headphone	Namely, Monitoring mode, left and right channels are the same, and 10 dB higher than mono channel.
	-	Decrease the output volume.
	+	Increase the output volume.

	RX	Adjust the receiver gain between -15 to +15 dB. The default value is 0 dB. Then receiver gain can be adjusted in headset mode only.
	TX1	Adjust the transmitter 1 gain between -15 to +15 dB. The default value is 0 dB.
	TX2	Adjust the transmitter 2 gain between -15 to +15 dB. The default value is 0 dB.
	Auto Gain Off	Tap  to enable the auto gain.
	Auto Gain On	When enabled, the microphone gain will automatically change according to the realtime volume. The gain will be lower accordingly when the real-time volume is higher, and vice versa. Tap to  to disable the auto gain.

	Original	Captures high-fidelity audio.
	Vocal Boost	Reduces ambient noise and improves voice intelligibility.
	Low Cut	The receiver removes low frequencies of audio signals, eliminating low-end noise.
	Low Gain	When recording loud sounds, switching to low gain mode reduces the volume by 20 dB for minimizing distortion. In this mode, the maximum sound pressure level can reach 130 dB.
	Auto Recording	When the function is activated, onboard recording will be automatically enabled every time the transmitter is switched on.
	32bit Recording	The transmitter defaults to recording files at 48 kHz 24-bit, but the user can set it to record at 48 kHz 32-bit float. For more details, please refer to the "32-bit Float Recording Feature" below.

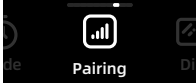
	Speaker Disabled	Tap  to enable the speaker.
	Speaker Enabled	Tap  to disable the speaker.
		Tap to turn on or off the timecode. When the timecode is enabled, the transmitter onboard recording will be turned on automatically. The onboard recording files are attached to a sequence of numbers in order to precisely label their timing.
	Framerate	Select 23.98fps, 24fps, 25fps, 29.97DF, 29.97fps, or 30fps.
	Running	Select free running or real-time running mode.
	Timecode Mode	Five timecode modes are available for choosing. Refer to Timecode Mode below for details.

	TX1	Tap Pairing to connect the receiver with the transmitters. If TX1's status indicator glows solid blue, TX1 is successfully paired with the receiver. The same applies to TX2.
	TX2	
	Brightness	Adjust the screen brightness.
	Display Time	Select the desired setting for timeout of the display time among 10s, 30s, 60s, always on.
	Time	The date and time of the recording files can be set.
	Headset NC	Tap to enable or disable the headset noise cancellation.
	Storage	Indicates the remaining recordable hours of the transmitter. On this page, tap TX1 or TX2 to confirm or cancel to format TX1 or TX2 storage.
	Version	Indicates the serial number and version of the transmitters and receiver.

	Language	Tap to set the receiver displaying language as English or Simple Chinese.
	Reset	Tap to access its sub menu to cancel or confirm resetting. After selecting Confirm, the receiver's relevant parameters will be restored to the default factory values. (Please use it with caution.)

L	Indicates the left channel.
R	Indicates the right channel.

- There are 5 kinds of timecode modes for the user to choose.

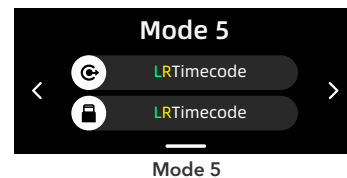
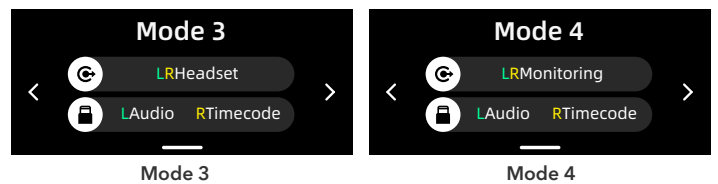
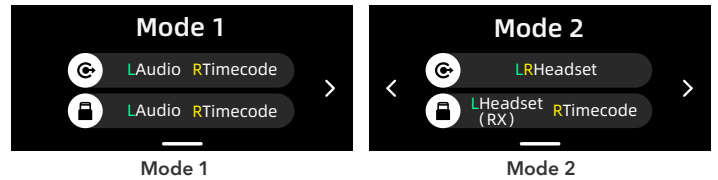



32-bit Float Recording Feature

The Saramonic Ultra transmitter supports recording audio in a 32-bit float file format. This format allows for capturing an extremely wide range of volume levels, ensuring that even if the sound exceeds 0 dB, it will not cause distortion or audio level spikes. Note that 32-bit float recording is only applicable to the onboard recording of the Saramonic Ultra transmitter and will not affect the recording format of the camera.

Timecode Mode

Timecode is a specific code for each frame in audio or video, which perfectly synchronizes your audio or video. It labels every clip with the exact time so that users can quickly find a specific frame, saving time in the editing process. Under the Timecode Mode menu, the user can set the timecode mode.

- Icon Description

	Indicates that audio is output from the 3.5 mm multi-functional output.
	Indicates that audio is output from the Lightning or USB-C adapter.

Transmitter Onboard Recording

- Press the transmitter's REC button to enable its onboard recording. Or activate the "Auto Recording" mode so that the transmitter can start recording audio as soon as it is switched on. To activate the "Auto Recording" mode, please refer to Receiver Touchscreen Operation.
- The transmitter can record up to 15 hours of 48 kHz 24-bit audio, and up to 10 hours if it records at the 48 kHz 32-bit sampling rate.
- Files are automatically split every 30 minutes, making it quickly to find the desired recording segment.
- By default, the recording files are named in the format of "DATE-TIME.WAV". Up to 999 recording files can be created.
- The transmitter comes with an EMMC chip with 8 GB of storage. If the 8 GB memory is full, the original file will be automatically overwritten with the latest file from the beginning.
- When the transmitter's USB-C charging port / data export is connected to a computer

using the included USB-C to USB-C data cable, the onboard recording files can be exported.

- The transmitter's storage can be formatted through the receiver's menu settings.

! **Note**

1. Onboard recording will remain on even the mute function is activated, but there is no sound in the onboard recording file.
2. Onboard recording cannot be turned on when reading files.

Specifications

Transmitter (TX)

Transmission Type	2.4 GHz digital frequency
Modulation	GFSK
Antenna	PIFA antenna
Operating Range (without obstacles)	1 RX with 2 TX: 300 m (with external antenna); 250 m (without external antenna)
RF Output Power	<20 dBm
Distortion	≤0.1%
Frequency Response	20 Hz to 20 kHz
Sampling Rate	Wireless recording: 48 kHz 24-bit
	Onboard recording: 48 kHz 24-bit or 48 kHz 32-bit float
Signal-to-noise Ratio	> 90 dB
Audio Input	In-built microphone, 3.5 mm TRS
Reference Audio Input Level	-30 to -42 dBV (MIC input, 0 dB attenuation)
Max SPL	130 dB SPL (In low gain mode, the Max SPL can reach 130 dB. Please connect to the Saramonic App and set the low gain mode on this app)
Storage	8 GB
Port for Reading Audio Files	USB-C Port
Power Supply	In-built lithium-ion battery
In-built Battery Capacity	495 mAh
Battery Life	Approx. 6 hours
Charging Time	Approx. 1.5 hours (via charging case or USB-C charging port) (5 V / 1 A)

Weight	35g
Dimensions	45.5 × 33.5 × 15 mm (L × W × H, clip height not included)
IP Rating	IPX5
Operating Temperature	0°C to 50°C
Storage Temperature	-20°C to 50°C

Receiver (RX)

Transmission Type	2.4 GHz digital frequency
Modulation	GFSK
Antenna	PIFA antenna
Operating Range (without obstacles)	1 RX with 2 TX: 300 m (with external antenna); 250 m (without external antenna)
RF Output Power	<20 dBm
Distortion	≤0.1%
Frequency Response	20 Hz to 20 kHz
Sampling Rate	Wireless recording: 48 kHz 24-bit
	Onboard recording: 48 kHz 24-bit or 48 kHz 32-bit float
Signal-to-noise Ratio	>90 dB
Audio Input	3.5 mm multi-functional output
Audio Output	3.5 mm multi-functional output
Monitoring Port	3.5 mm multi-functional output(supports real-time monitoring or playback monitoring, and 3.5 mm TRS headphones)
External Antenna Port	TS9 port

Power Supply	In-built lithium-ion battery
In-built Battery Capacity	465 mAh
Battery Life	Approx. 6 hours
Charging Time	Approx. 1.5 hours (via charging case or USB-C charging port) (5 V / 1 A)
Weight	36g
Dimensions	54 × 34.1 × 18 mm (L × W × H, clip height not included)
Operating Temperature	0°C to 50°C
Storage Temperature	-20°C to 50°C

Charging Case

Battery Capacity	2900 mAh
Charging Time	Approx. 2 hours (5 V 2 A)
Charging Connector	USB-C port
Times for Charging TX and RX	>1 time (for 2 TX and 1 RX)
Weight	210.5g
Dimensions	117 × 48.5 × 62.4 mm (L × W × H)
Operating Temperature	0°C to 50°C
Storage Temperature	-20°C to 50°C

声明

请在使用前仔细阅读本手册，并严格按照说明进行操作和存储。请妥善保存好说明书，以供将来参考。如果用户手册不能帮助您解决某些问题，请向零售商寻求帮助或给我们发送电子邮件：info@saramonic.com

注意事项

1. 请勿擅自拆开机壳
2. 请勿将本机靠近热源，如散热器、聚光灯或其他产生热量的设备
3. 电池不可自行更换
4. 请使用柔软的干布清洁本设备
5. 在使用和储存时，请注意防尘和防潮
6. 为获得最佳拾音效果，请勿将手放在麦克风咪头上。

概述

Saramonic Ultra 是一款双通道旗舰无线麦克风系统，无线传输距离可达 300 米*，能够在广播、演讲、移动新闻等应用场合提供专业品质的音质。采用全新自研降噪算法技术和低切声音模式，有效去除杂音和背景噪声。Saramonic Ultra 发射器抗水性能达到了 IPX5 级，在恶劣的环境中也一样表现出色。

Saramonic Ultra 集 32-bit 浮点内录、时间码、和先进的设置功能于一体，其专业性提升至一个全新的高度。32-bit 浮点内录功能支持发射器独立录制音频，可实现录音文件实时存档。搭配时间码功能，用户在后期制作中可快速实现音频完美同步。接收器自带 1.1 寸触控彩屏，无线信号强度、降噪、电量、音量、时间码、录音状态等信息一目了然，用户在录制过程中可轻松调节各类参数。

Saramonic Ultra 系统使用方式多样。除内置麦克风，发射器也可搭配领夹麦使用（部分套装不含领夹麦，请以实际购买套装为准）。接收器具有 3.5 mm 多功能输出口，可以将音频从接收器输出到相机、混音器等专业设备。此外，使用附带的 USB-C、Lightning 两种转接头，可以将音频从接收器输出到手机、平板、电脑等移动设备。

* 在室外空旷无干扰环境下测得，300 米传输距离需使用外置天线才能实现。

特点

- 内置时间码，声画同步
- 130 dB 防爆音
- 外置天线，信号更稳
- 智能降噪，自动增益
- 32-bit 浮点内录，8 GB 容量
- IPX5 防水

包装清单

Saramonic Ultra 01 (黑色)	
发射器	×2
接收器	×1
3.5 mm TRS 转 TRS 音频线	×1
USB-C 转接头	×1
磁吸片	×2
收纳袋	×1
充电盒	×1
USB-C 转 USB-C 数据线	×1
Lightning 转接头	×1
防风毛套	×2
外置天线	×1

Saramonic Ultra 02 (白色)	
发射器	×2
接收器	×1
3.5 mm TRS 转 TRS 音频线	×1
USB-C 转接头	×1
磁吸片	×2
收纳袋	×1
充电盒	×1
USB-C 转 USB-C 数据线	×1
Lightning 转接头	×1

防风毛套	×2
外置天线	×1

防风毛套	×2
外置天线	×1

Saramonic Ultra 03 (黑色)	
发射器	×2
接收器	×1
充电盒	×1
领夹麦	×2
3.5 mm TRS 转 TRS 音频线	×1
USB-C 转接头	×1
磁吸片	×2
收纳袋	×1
USB-C 转 USB-C 数据线	×1
Lightning 转接头	×1
防风毛套	×2
外置天线	×1

Saramonic Ultra 05 (黑色)	
发射器	×1
接收器	×1
3.5 mm TRS 转 TRS 音频线	×1
USB-C 转接头	×1
磁吸片	×1
收纳袋	×1
USB-C 转 USB-C 数据线	×1
Lightning 转接头	×1
防风毛套	×1
外置天线	×1

Saramonic Ultra 04 (白色)	
发射器	×2
接收器	×1
充电盒	×1
领夹麦	×2
3.5 mm TRS 转 TRS 音频线	×1
USB-C 转接头	×1
磁吸片	×2
收纳袋	×1
USB-C 转 USB-C 数据线	×1
Lightning 转接头	×1

Saramonic Ultra 06 (白色)	
发射器	×1
接收器	×1
3.5 mm TRS 转 TRS 音频线	×1
USB-C 转接头	×1
磁吸片	×1
收纳袋	×1
USB-C 转 USB-C 数据线	×1
Lightning 转接头	×1
防风毛套	×1
外置天线	×1

配件 (单独出售)	
SONY 相机连接器	
领夹麦	

产品结构

发射器 (TX)

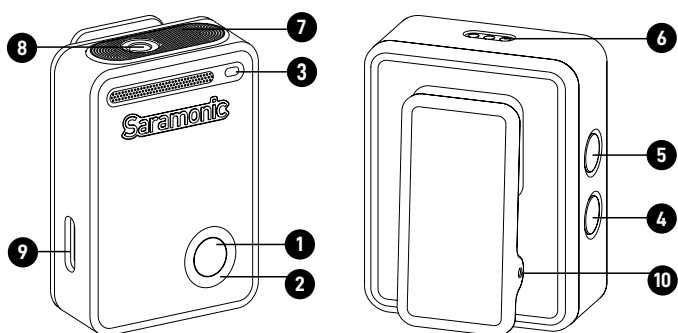

1 电源按键

- 长按 2 秒开机或关机。
- 短按开启或关闭静音。
- 当接收器连接手机时，双击发射器电源按键可控制手机拍摄（适用于支持音量键控制拍照的手机）。

2 指示灯状态

状态	指示灯
未连接	蓝灯慢闪
连接成功	蓝灯常亮
降噪已开启	绿灯常亮
低电量	红灯闪烁
充电中	红灯常亮
充满电	蓝灯 / 绿灯常亮
对码中	蓝灯快闪

- 发射器进入对码时，其指示灯呈蓝灯快闪（持续 2 分钟），等待与接收器对码。超时将退出对码，指示灯转为蓝灯慢闪。
- 发射器处于低电量时请及时充电，否则发射器将在 10 分钟后自动关机。
- 当发射器多个功能被激活时，其指示灯将优先显示其中一个功能。指示灯优先级：充电 > 低电 > 未连接 > 降噪。

3 录音指示灯

状态	指示灯
静音模式开启	红灯闪烁
内录模式	红灯常亮
内录无法开启	红灯闪烁三次后熄灭

- 读取内录的录音文件时，内录将无法开启。
- 指示灯优先级：静音 > 内录。



当发射器放入充电盒内充电时，其录音指示灯用作充电指示灯。

状态	指示灯
充电中	红灯常亮
充满电	熄灭

4 REC 按键（录音按键）

短按开启或关闭内录。

5 NC 按键（降噪按键）

短按开启或关闭降噪功能。

6 充电触点

与充电盒触点连接后即可充电。

7 内置麦克风

8 3.5 mm TRS 输入孔

可外接领夹麦使用。

9 USB-C 充电口 / 数据导出口

接入标配的 USB-C 转 USB-C 数据线给发射器充电。也可通过此接口读取到机身内录存储卡内的录音文件。

10 磁吸背夹

可直接夹在衣服上使用，或搭配磁吸片吸附在衣服上使用。

接收器 (RX)

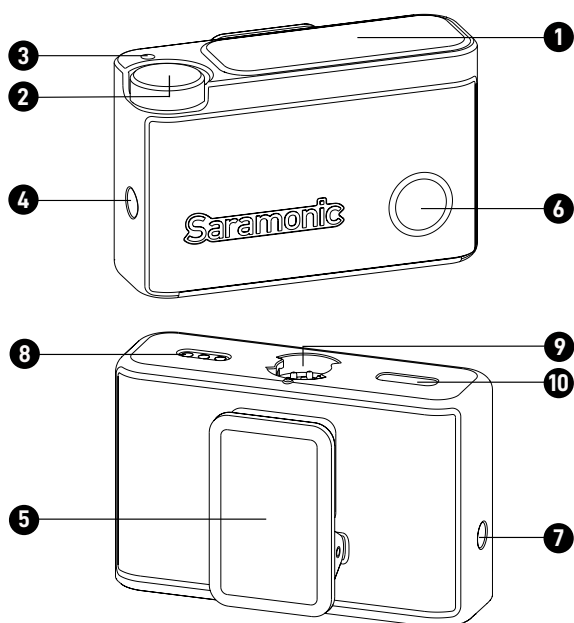

1 触摸屏

显示无线信号强度、降噪、发射器与接收器的电量、充电状态、麦克风增益、实时输入音量、输出音量、输出模式、时间码等信息。详情请参考“接收器触摸屏设置”。

2 旋钮

当接收器触摸屏处于设置界面时，转动旋钮可选择相关设置项，短按旋钮进入子菜单页面。

3 爆音提示灯

音量过高，可能会引起爆音。出现爆音时，该指示灯呈红灯常亮。无爆音后1秒，该指示灯熄灭。

4 外置天线接口

支持连接标配的外置天线。

5 背夹

可安装至相机冷靴口。

6 电源按键

- 长按2秒开机或关机。
- 短按锁定或解锁屏幕。锁定屏幕可避免在录制过程中意外的操作。

7 3.5 mm 多功能输出口

支持单声道 / 立体声 / 安全音轨 / 耳麦 / 耳机五种模式，在接收器设置菜单中点击输出模式即可切换。默认模式为单声道。详情请参考“接收器触摸屏设置”。

8 充电触点

与充电盒触点连接后即可充电。

9 连接触点

使用标配的 Lightning / USB-C 转接头，可将接收器连接至手机、电脑等移动设备。

10 USB-C 充电口

可接入标配的 USB-C 转 USB-C 数据线给接收器充电。

充电盒

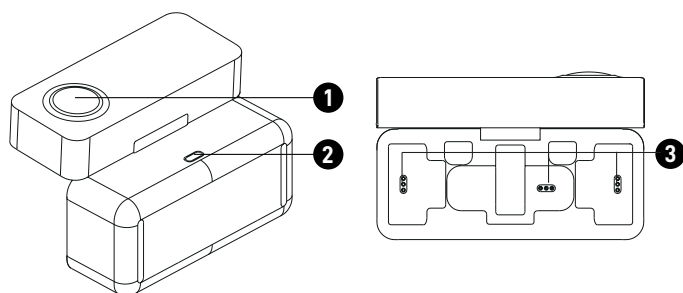

1 指示灯

- 充电盒接入电源充电时，该指示灯显示充电盒充电的状态。

充电盒电量	指示灯
0 至 33%	红灯呼吸
34% 至 76%	橙灯呼吸
77% 至 100%	白灯呼吸
充满电	白灯常亮

- 充电盒未接入电源（非充电状态）时，打开充电盒或在盒内放入产品后，该指示灯将显示充电盒当前电量。

充电盒电量	指示灯
0 至 10%	红灯闪烁（不呼吸）
10 至 33%	红灯常亮
34% 至 76%	橙灯常亮
77% 至 100%	白灯常亮

⚠ 注意

1. 指示灯呈红灯闪烁（不呼吸）时，充电盒电量 < 10%，此时充电盒无法给产品充电，请尽快给充电盒充电。
2. 充电盒电量 > 10% 或充电盒接入 USB-C 转 USB-C 数据线充电时，产品从充电盒中取出将自动开机；产品在充电盒内 1 分钟无操作，自动关机。

② USB-C 充电口

接入标配 USB-C 转 USB-C 数据线给充电盒自身充电。

③ 充电触点

操作指南

发射器佩戴

- ① 在户外录音或有风的环境下，若想要更清晰的录音效果，可将防风毛套安装至发射器内置麦克风上。若外接领夹麦，需连接至发射器的 3.5 mm TRS 输入孔。

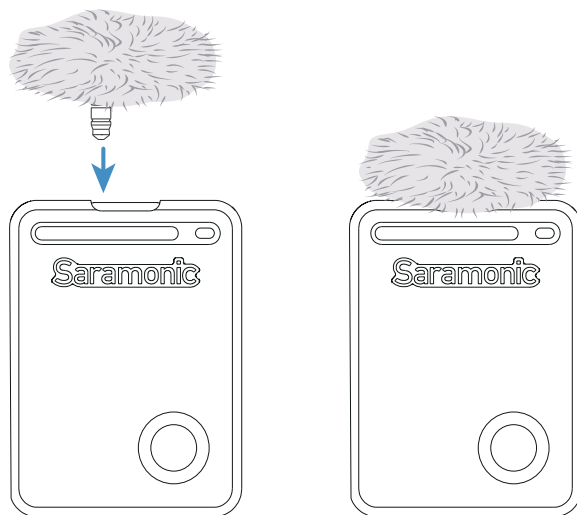

- ② 发射器可直接夹在衣服上使用，也可通过标配的磁吸片将带磁吸背夹的发射器吸附在衣服上。

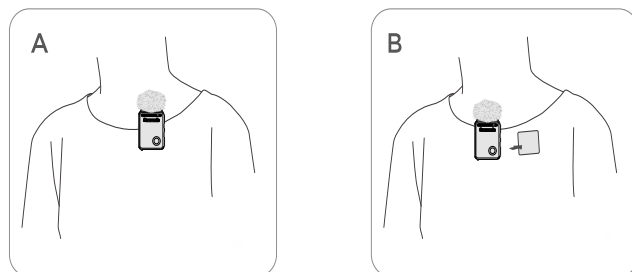

接收器安装天线

接收器自带内置天线，也支持安装外置天线。将标配的外置天线插入接收器的外置天线接口。外置天线连接后，接收器将自动使用外置天线。取下外置天线后，接收器将使用内置天线。

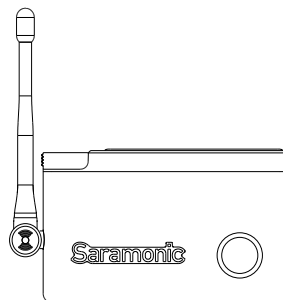

提示：使用外置天线，可有效提高抗干扰性能。

发射器与接收器对码

Saramonic Ultra 系统内的发射器与接收器出厂默认已配对。发射器与接收器开机后会自动对码。对码成功后，发射器的状态指示灯均呈蓝灯常亮。若发射器与接收器断开，可通过以下两种方式对码：

方法一：充电盒自动对码

将发射器和接收器放进充电盒 5 秒后，将自动对码成功。

方法二：手动对码

- 1 发射器在关机状态下，长按电源按键 5 秒，其指示灯呈蓝灯快闪进入配对模式。
- 2 长按接收器电源键 2 秒将接收器开机，在接收器屏幕向左滑动进入设置菜单页面，选择对码菜单，点击对码。
- 3 对码成功，发射器的状态指示灯均呈蓝灯常亮。

连接移动设备使用

- 使用标配的 Lightning / USB-C 转接头可将接收器连接至手机、平板、或电脑等移动设备，发射器录制的音频将传输至接收器所连接的移动设备。打开已连接设备的录音机或相机即可开始录音。支持通过 Lightning / USB-C 转接头连接电源给手机充电。

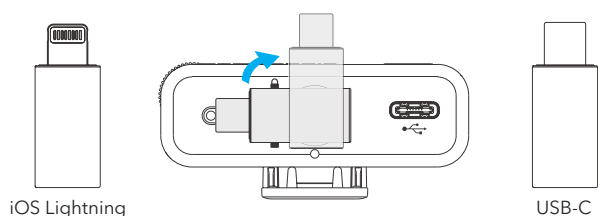

- 当接收器与手机、电脑等设备连接时，推荐使用 Saramonic 应用程序录制音频。用户还可通过该应用控制发射器和接收器，以及升级固件等。

- 1 请用手机扫描下方的二维码，下载并安装 Saramonic 应用程序。



- 2 启动 Saramonic 应用程序，点击🎙️即可开始录音。



- 3 点击屏幕左上角🏠，然后点击“Saramonic Ultra 设备管理”即可进入接收器 (RX)、发射器 (TX) 控制页面。



控制 RX 页面：



屏幕上滑进入 TX1 和 TX2 控制页面：



- 4 点击更多设置 > 声音模式，选择低增益模式，最大声压级可达到 130 dB，轻松避免爆音与失真，显著提升录音质量。



连接相机使用

使用标配的 3.5 mm TRS 转 TRS 音频线将接收器的 3.5 mm 多功能输出口连接至相机、混音器等设备，发射器录制的音频将传输至接收器连接的相机。

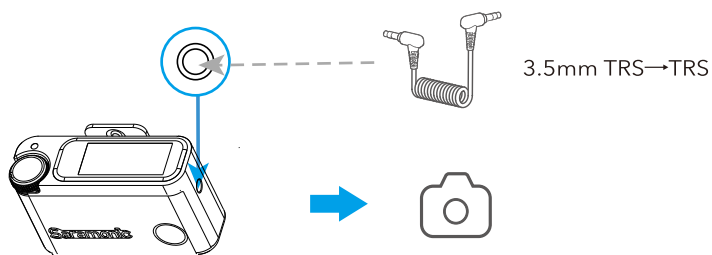

接收器触摸屏设置

主界面预览

显示无线信号强度、降噪、发射器与接收器的电量、充电状态、麦克风增益、实时输入音量、输出音量、输出模式、时间码等信息。下面以连接两个发射器为例：



主界面上方显示发射器状态

	显示发射器 1 (TX1)、发射器 2 (TX2) 与接收器之间的无线信号强度。当只连接单个发射器时，则只显示一个发射器的信息。
	表示发射器已开启内录。

	表示发射器已开启降噪功能。
	显示发射器的电量、充电状态。

主界面中间显示发射器音量状态

	显示麦克风增益。
	显示实时输入音量。
	表示发射器已静音。

主界面下方显示接收器状态

	显示输出模式，可在接收器菜单中设置为单声道 / 立体声 / 安全音轨 / 耳麦 / 耳机输出模式。详情请参考“菜单页面预览→设置菜单”。
	显示输出音量。
	表示接收器触摸屏已锁定。短按接收器电源按键锁定或解锁屏幕。
	显示时间码已开启。
	表示接收器已开启耳麦降噪功能。
	显示接收器的电量、充电状态。

- 快捷设置：当接收器触摸屏处于主界面时，短按旋钮可选择主界面上方或下方。选择主界面上方后，转动旋钮可调节麦克风增益。选择主界面下方，转动旋钮可调节输出音量。

菜单预览

进入菜单界面后，如果超过 20 秒不操作，将自动跳转回主界面。

发射器设置菜单

- 在主界面左侧下滑进入发射器 1 (TX1) 设置界面，在主界面右侧下滑进入发射器 (TX2) 设置界面。点击相应图标可控制静音、降噪及录音。



- 上滑退出发射器设置界面，返回主界面。





设置菜单

- 在主界面向左滑动进入设置菜单。
- 进入设置菜单后，向右或向左滑动选择主菜单。也可转动旋钮进行选择。
- 在设置菜单页面，点击主菜单图标或短按旋钮进入子菜单，选择或点击相关设置项即可确认设置。
- 向上滑返回上级菜单。

主菜单	子菜单	说明
	单声道	左右声道输出的内容一致。
	立体声	左右声道输出分别对应发射器 1 和发射器 2 两个声源。
	安全音轨	右声道的输出增益比左声道小 6 dB，以防声音过爆。
	耳麦	接收器上的 3.5 mm 多功能输出口支持接入带麦克风功能的耳机。
	耳机	即监听模式，左右声道一致，比单声道大 10dB。
	—	减小输出音量。
	+	增加输出音量。
	RX	调节接收器的增益。增益范围：-15 ~ +15dB，默认值为 0 dB。仅耳麦模式下可调节接收器的增益。
	TX1	调节发射器 1 的增益。增益范围：-15 ~ +15dB，默认值为 0 dB。
	TX2	调节发射器 2 的增益。增益范围：-15 ~ +15dB，默认值为 0 dB。

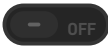
	自动增益关闭	点击  图标开启自动增益。
	自动增益开启	自动增益开启后，麦克风增益将根据实时输入音量大小自动变化，音量大时增益变小，音量小时增益变大。点击  图标关闭自动增益。
	原声	采取高保真拾音。
	人声增强	突出人声，录制的音频更清晰。
	低切	接收器自动滤除低频噪音。
	低增益	在录制大音量声音时，切换至低增益模式可降低 20 dB 音量，减少爆音。此模式下最大声压级可达 130 dB。
	自动录制	该功能启用后，发射器每次开机将自动开启内录功能。
	32bit 录制	发射器默认录制 48 kHz 24-bit 文件，用户也可设置为 48 kHz 32-bit 浮点录制。详情请参考下方“32-bit 浮点录音功能”。
	外放关闭	点击  图标开启外放。
	外放开启	点击  图标关闭外放。

		点击可开启 / 关闭时间码。时间码开启后，发射器自动打开内录，录音文件自带时间码信息。
	帧率设置	可选择帧率为 23.98fps、24fps、25fps、29.97DF、29.97fps、30fps。
	运行模式	可选择自由运行或实时运行。
	时间码模式	五种时间码模式可选。详情请参考下方“时间码模式”。
	TX1	点击“对码”，将发射器与接收器码。若发射器与接收器连接成功，发射器的状态指示灯呈蓝灯常亮。
	TX2	
	显示亮度	调节屏幕亮度。
	显示时间	调节屏幕自动息屏的时间，可选择显示时间为 10 秒、30 秒、60 秒、或常亮。

	时间设置	可设置录音文件的日期与时间。
	耳麦降噪	点击开启或关闭耳麦降噪。
	内存	显示发射器的可录制时间。在此菜单页，点击 TX1 / TX2，可选择将发射器 1 / 发射器 2 内存格式化。
	版本	显示接收器与发射器的序列号与版本信息。
	语言设置	可将接收器触摸屏显示的语言设置为 English (英语) 或简体中文。
恢复出厂	点击进入下一级菜单，取消或确认恢复出厂设置。恢复出厂设置后，接收器的相关参数将被恢复到默认出厂值。（请谨慎使用此功能）	

32-bit 浮点录音功能

Saramonic Ultra 的发射器支持以 32 位浮点文件格式录制音频。32 位浮点位深的音频文件能够记录非常宽的音量级别范围，即使声音超过 0 dB，录制的音频也不会失真或过曝

注：32 位浮点仅适用于 Saramonic Ultra 的板载录音，不支持改变相机的录制格式。

时间码模式

时间码是音频或视频中的每一帧画面的特定编码。时间码能将录制的文件整理成按时间有序排列的文件，用户可快速找到视频中特定的一帧画面，

大量节省了后期制作的时间。选择并点击时间码模式菜单，进入下一级菜单可设置时间码模式。

图标说明

	表示 3.5 mm 多功能输出口输出
	表示 Lightning / USB-C 转接头输出
	表示左声道
	表示右声道

时间码可设置为以下 5 种模式：



发射器内录

- 短按发射器 REC 按键（录音按键）即可开启内录功能；也可提前在接收器菜单中设置内录在发射器开机时自启动。
- 在 48 kHz 24-bit 采样率下，最高支持内录时长约为 15 小时；在 48 kHz 32-bit 采样率下，最高支持内录时长约为 10 小时。
- 录音满 30 分钟后将自动分割文件，便于快速查找想要的录音片段。
- 录音文件默认命名格式为“年 - 月 - 日 - 时 - 分 - 秒 .WAV”，最高支持 999 个录音文件。
- 内置 EMMC 芯片可保存约 8 GB 的音频文件，内存录满后将自动循环覆盖。
- 发射器可通过标配的 USB-C 转 USB-C 数据线连接 USB-C 充电口 / 数据导出口至电脑导出内录文件。

- 可通过接收器菜单设置格式化发射器存储。

⚠ 注意

1. 开启静音模式，内录将保持开启，但是内录文件无声音。
2. 读取文件时不可开启内录。

参数

发射器 (TX)

传输方式	2.4 GHz 数字频段
信号调制	GFSK
天线类型	PIFA 天线
操作距离 (无障碍)	一拖二: 300 m (有外置天线); 250 m (无外置天线)
射频输出功率	<20 dBm
失真	≤ 0.1%
频率响应	20 H 至 20 kHz
采样率	无线采样率 48 kHz 24-bit
	内录采样率 48 kHz 24-bit 或 48 kHz 32-bit 浮点
咪头信噪比	> 90 dB
音频输入接口	内置麦克风, 3.5 mm TRS
参考音频输入电平	-30 至 -42 dBv (麦克风输入, 0 dB 衰减)
最大声压级	130 dB SPL (低增益模式时, 最大声压级可达到 130 dB。请连接 Saramonic App, 在该软件上设置低增益模式)
内置存储空间	8 GB
文件读取接口	USB-C 接口
供电方式	内置锂电池供电
内置电池容量	495 mAh
续航时长	> 6 小时
电池充电时长	约 1.5 小时 (充电盒及 USB-C 口充电) (5 V / 1 A)
重量	35g
尺寸	45.5 × 33.5 × 15 mm (长 × 宽 × 高, 不含背夹高度)
防水等级	IPX5
工作温度	0° C 至 50° C
贮存温度	-20° C 至 50° C

接收器 (RX)

传输方式	2.4 GHz 数字频段
信号调制	GFSK
天线类型	PIFA 天线
操作距离 (无障碍)	一拖二: 300 m (有外置天线); 250 m (无外置天线)
射频输出功率	<20 dBm
失真	≤ 0.1%
频率响应	20 Hz 至 20 kHz
采样率	无线采样率 48 kHz 24-bit 内录采样率 48 kHz 24-bit 或 48 kHz 32-bit 浮点
信噪比	>90 dB
音频输入接口	3.5 mm 多功能输出口
音频输出接口	3.5 mm 多功能输出口
监听接口	3.5 mm 多功能输出口 (支持实时监听与回放监听, 支持 3.5 mm TRS 耳机)
外置天线接口	TS9 接口
供电方式	内置锂电池供电
内置电池容量	465 mAh
续航时长	> 6 小时
电池充电时长	约 1.5 小时 (充电盒及 USB-C 口充电) (5 V / 1 A)
重量	36g
尺寸	54 × 34.1 × 18 mm (长 × 宽 × 高, 不含背夹高度)
工作温度	0° C 至 50° C
贮存温度	-20° C 至 50° C

充电接口	USB-C 接口
可供循环充电次数	>1 次 (2*TX+1*RX)
重量	210.5g
尺寸	117 × 48.5 × 62.4 mm (长 × 宽 × 高)
工作温度	0° C 至 50° C
贮存温度	-20° C 至 50° C

充电盒

内置电池容量	2900 mAh
充电时长	约 2 小时 (5 V 2 A)



For better recording experience, the application Saramonic is recommended.

为获得更好的录制体验, 推荐使用枫笛 Saramonic 自主研发应用软件 Saramonic。



Scan the QR code and follow us!

扫描微信二维码关注枫笛公众号!

Shenzhen Jiayz Photo Industrial., Ltd

深圳市长丰影像器材有限公司

A16 Building, Intelligent Terminal Industrial Park of Silicon Valley

Power, Guanlan, Longhua District, Shenzhen, China

深圳市龙华区观澜街道大富工业区硅谷动力智能终端产业园A16栋